

2, 3, or 4 Lamp
T5, T5HO, or T8
Prismatic Acrylic Lens

CONSTRUCTION/FINISH

- A quality low-profile troffer with specification features for NEMA “G” grid, NEMA “NFG” narrow face grid, NEMA “GR” grid regressed, NEMA “NFSG” narrow faced slot grid, or NEMA “F” flange ceiling types.
- 3” nominal housing depth, 3-3/16” maximum depth.
- Smooth rolled edges on all four sides for easy handling.
- Die-formed one piece housing includes stiffening embosses and provides increased rigidity.
- Housing is multi-stage phosphate treated for maximum corrosion resistance and finish coat is high reflectance baked white enamel.
- Lamp pin openings in housing ends for easier relamping (can be relamped without using openings).
- Integral baffling system to prevent light leaks.
- 2 sets of integral grid clips (wraparound and fold out) for maximum mounting flexibility.
- Integral wire hanger holes for independent wire suspension.
- Embosses with holes provided in housing end for screwing to T-bar if desired.
- On T8 models, a single lamp can be changed without disturbing other lamps or wireway cover.

- 7/8” K.O.’s provided in each end cap for through wiring.
- Factory installed access plate in housing top includes 7/8” hole with rolled edge and 7/8” K.O.
- Carton includes integral carrying handle for easy handling.

ELECTRICAL

- cULus listed for damp locations.
- Self-contained fluorescent emergency power packs can be incorporated, listed for dry locations.
- Rotating ring locking lampholder is standard for secure and positive retention of lamps.

ENCLOSURES

- Full “C” channel door frames for improved lens support and reduced shipping damage.
- Flat steel door frame features smooth rolled edges inside and outside.
- All door frames have mitered corners.
- All door frames use T-hinges and can be hinged and latched from either side.
- Opposable spring loaded latches are standard for easy operation and consistent retention.

CATALOG NUMBER

2								
WIDTH	NO. OF LAMPS	DOOR FRAME	DOOR FINISH	LENS	VOLTAGE	OPTIONS		
2 – 2'	(not included) 2 3 4	BLANK – Flat Steel FA – Flat Alum. RA – Regr. Alum.	BLANK – White Door B – Black Door	01 – Pattern 12 prismatic acrylic 12 – DB-12, .125” nominal 19 – DB-19, .156” nominal 21 – Pattern 12, .125” nominal 30 – 1/2”x1/2”x1/2” silver plastic louver 34 – 1-1/2”x1-1/2”x1-1/2” silver plastic louver 52 – 3/4”x3/4”x1/2” silver plastic louver See Sheet 420-SR for other options.	120 277 347 UNV – Universal voltage, 120-277 volt	1/2 – One 2-lamp ballast 1/3 – One 3-lamp ballast 1/21 – 2-lamp & 1-lamp ballasts 1/4 – One 4-lamp ballast 2/2 – Two 2-lamp ballasts EB – Electronic ballast, <20% THD EB10I – T8 electronic ballast, instant start, <10% THD EB10R – Electronic ballast, program rapid start, <10% THD EBHE – T8 electronic ballast, high efficiency, std. ballast factor EBLHE – T8 electronic ballast, high efficiency, low ballast factor EBHHE – T8 electronic ballast, high efficiency, high ballast factor EBSD – T8 electronic ballast, step dimming, std. (.88) ballast factor EBD – Electronic dimming ballast ESNOLP – Electronic ballast for energy saving (25/28/30W) T8 lamps, use when lamps are not specified with the luminaire E1 – DEB-1 emerg. ballast, T8, 350-450 lumens, 120/277V E1CAN – DEB-1 emerg. ballast, Canada market, T8, 350-450 lumens, 120/347V E7 – DEB-7 emerg. ballast, T8, 600-700 lumens E5 – DEB-5 emerg. ballast, US or Canada market, T8, 1100-1400 lumens, 120/277V ESCAN – DEB-5 emerg. ballast, Canada market, T8, 1100-1400 lumens, 120/347V ESST – DEB-5ST emerg. ballast w/self test, T8, 1100-1400 lumens E7LP – DEB-7LP emerg. ballast T8/T5/T5HO, 430-700 lumens E6LP – DEB-6LP emerg. ballast, US or Canada market, T8/T5/T5HO, 750-1325 lumens, 120/277V F1 – Installed flex, 3/8” diameter, 18 gauge, 3 wire, 6’ F2 – Installed flex, 3/8” diameter, 18 gauge, 4 wire, 6’ GLR# – Fusing, fast blow (# = number of ballasts) LPT735 – Installed T8 lamps, 70+ CRI, 3500K LPT835HL – Installed T8/T5 hi lumen lamps, 80+ CRI, 3500K 1W – 1-way gasketing, between lens & door frame (not avail. w/RA door) 2W – 2-way gasketing, 1W + gasketing between door frame & housing 3W – 3-way gasketing, 2W + gasketing for field installation between housing & ceiling SI – Specular insert (reflector)		
FIXTURE FAMILY	LAMP TYPE/WATTAGE							
TG8 – TG8 Troffer, Grid TF8 – TG8 Troffer, Flange	28 – 28WT5 (46”) 32 – 32WT8 (48”) 54HO – 54WT5HO (46”)							

JOB INFORMATION



DIMENSIONS

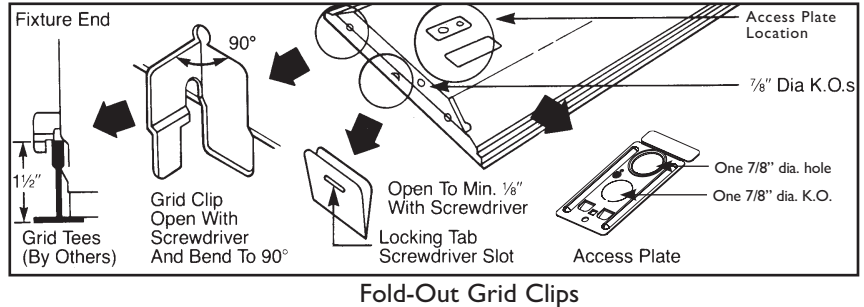
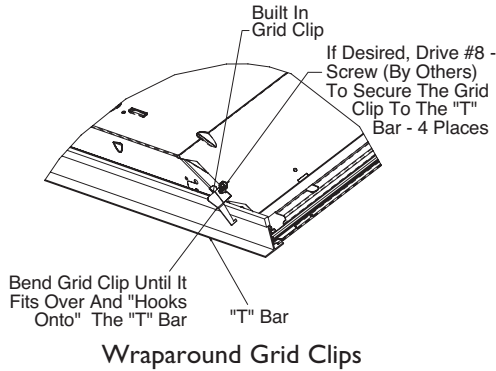
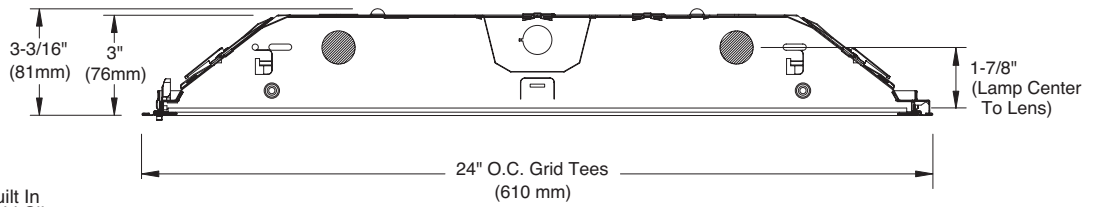

PHOTOMETRIC DATA

CATALOG # 2TG8232-01-1/2-EB LAMPS = F32T8 INPUT WATTS = 59 LER = FL-74
 TEST #22916 SMH=1.4 BALLAST = ELECTRONIC BALLAST FACTOR = .88 TER = 65
 COMPARATIVE YEARLY LIGHTING ENERGY COST PER 1000 LUMENS = \$3.24 BASED ON 3000 HRS. AND \$.08 PER KWH. FIXTURE EFFICIENCY= 87.1%

CANDLEPOWER			
Angle	End	45	Cross
0	1838	1838	1838
5	1841	1835	1827
10	1815	1821	1823
15	1774	1796	1818
20	1715	1761	1802
25	1631	1711	1778
30	1530	1643	1737
35	1411	1550	1667
40	1271	1416	1551
45	1111	1244	1373
50	931	1065	1154
55	747	872	931
60	572	653	709
65	430	445	514
70	329	289	361
75	260	201	251
80	193	156	176
85	102	94	94

MAINTAINED ILLUMINATION TABLE- Square Feet/ Fixture*					
■ 80-50-20 Reflectances (Ceiling-Wall-Floor) ■ LLF = 0.75 2850 Lumens/Lamp very clean ■ Room width divided by room height = 5 or more, 2 or 1					
Fixture Size & # of Lamps	Room Width Room Height =	Approx. Area (sq. ft.) per Fixture			
		10 ft-c	30 ft-c	50 ft-c	70 ft-c
2-Lamp T8	5	-	131	78	56
	2	-	90	54	39
	1	-	66	40	-

COEFFICIENT OF UTILIZATION						
p/c	20		70		50	
	80	70	50	30	50	30
RCR	0	104	104	104	101	101
	1	94	91	88	93	89
	2	86	80	75	84	79
	3	80	70	64	78	69
4	72	63	56	70	61	
5	67	56	48	66	56	
6	61	51	44	60	50	
7	57	46	39	56	46	
8	54	41	34	53	41	
9	50	39	32	48	38	
10	46	35	28	46	34	

AVERAGE LUMINANCE CD/SQ.M WITH 2850 LUMEN LAMPS			
ANGLE	END	45°	CROSS
45	2521	2823	3116
55	2090	2439	2604
65	1633	1690	1952
75	1612	1246	1556
85	1878	1731	1731

TYPICAL V.C.P.'s			
Room Size	Mounting Height		
	Lengthwise	Crosswise	
	8.5	10	8.5
30x30	60	65	60
40x40	57	61	57
60x30	63	67	62
60x60	53	56	53
100x100	50	52	51

LIGHT DISTRIBUTION			
DEGREES	LUMENS	% LAMP	% FIXTURE
0-30	1470	25.8	29.6
0-40	2433	42.7	49.0
0-60	4147	72.8	83.5
0-90	4966	87.1	100.0

LLF = 0.75 LLF = LIGHT LOSS FACTOR LLF = LDD X LLD X BF LDD = VERY CLEAN 0.94 CLEAN 0.90
 LLD = 0.91 @ 40% RATED LAMP LIFE BF = 0.88 ELECTRONIC BALLAST & T-8 LAMP (RELAMP AT 70% LAMP LIFE)

2 T G 8 2 32

CEILING TYPE

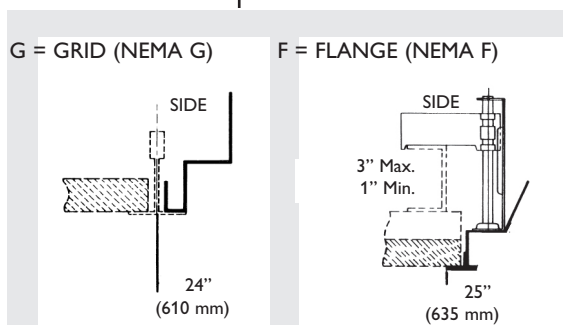

(NEMA Type G)
Lay-in acoustical ceilings using exposed grid suspension, with tees for fixtures on 24" x 48" spacing.

(NEMA Type F)
Flange for acoustical ceilings using concealed mechanical suspension. Swing-jack mounting brackets: adjustment 3" max. and 1" min. Refer to sheet 801-CL for cut-out information.

DIMENSIONS

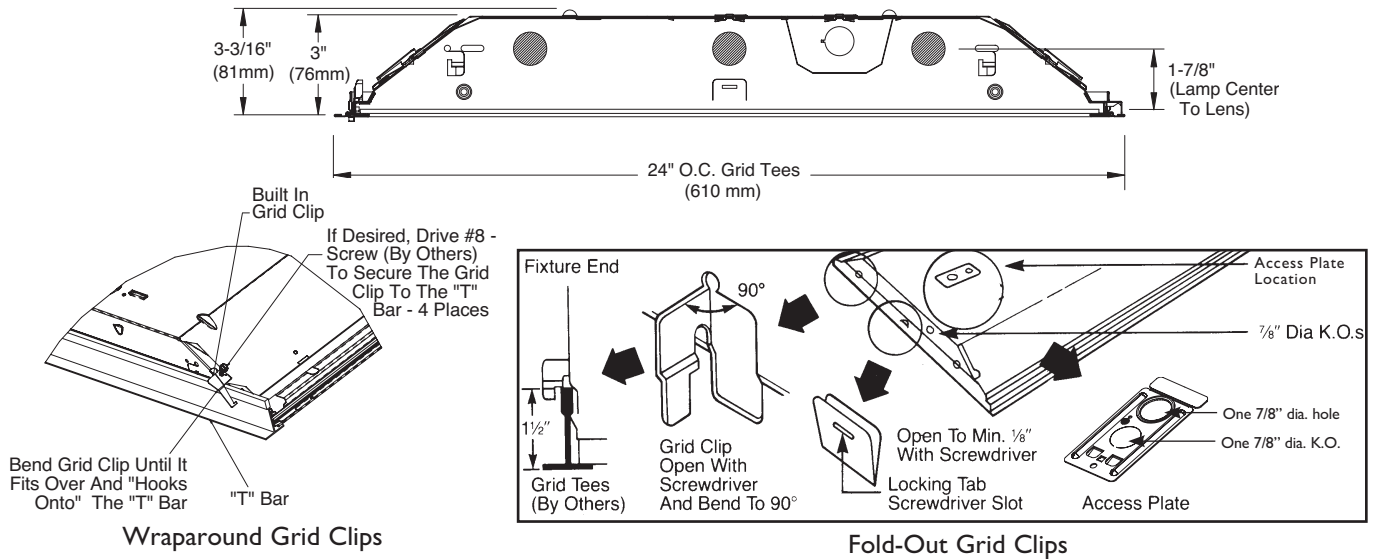

PHOTOMETRIC DATA

CATALOG # 2TG8332-01-1/3-EB
 TEST #22921 S/MH=1.4

LAMPS = F32T8
 BALLAST = ELECTRONIC BALLAST FACTOR = .88

INPUT WATTS = 84
 LER = FL-76
 TER = 67

COMPARATIVE YEARLY LIGHTING ENERGY COST PER 1000 LUMENS = \$3.16 BASED ON 3000 HRS. AND \$.08 PER KWH.

FIXTURE EFFICIENCY= 84.8%

CANDLEPOWER			
Angle	End	45	Cross
0	2708	2708	2708
5	2709	2703	2694
10	2673	2681	2688
15	2618	2645	2677
20	2526	2593	2657
25	2402	2518	2616
30	2253	2413	2544
35	2078	2269	2429
40	1867	2069	2247
45	1630	1818	1985
50	1365	1545	1663
55	1093	1263	1339
60	841	943	1019
65	634	643	741
70	481	419	518
75	377	291	362
80	279	225	257
85	145	133	149

MAINTAINED ILLUMINATION TABLE- Square Feet/ Fixture*						
■ 80-50-20 Reflectances (Ceiling-Wall-Floor) ■ LLF = 0.75 2850 Lumens/Lamp very clean ■ Room width divided by room height = 5 or more, 2 or 1						
Fixture Size & # of Lamps	Room Width Room Height =	Approx. Area (sq. ft.) per Fixture				
		10 ft-c	30 ft-c	50 ft-c	70 ft-c	100 ft-c
3-Lamp T8	5	-	-	114	82	57
	2	-	132	79	57	40
	1	-	97	58	42	-

*Observe Fixture S/MH Requirements for Specific Applications

AVERAGE LUMINANCE CD/SQ.M WITH 2850 LUMEN LAMPS			
ANGLE	END	45°	CROSS
45	3699	4125	4504
55	3058	3533	3746
65	2407	2441	2813
75	2337	1804	2244
85	2669	2449	2743

TYPICAL V.C.P.'s			
Room Size	Mounting Height		
	Lengthwise	Crosswise	
30x30	51	56	51 55
40x40	48	52	48 51
60x30	54	59	54 58
60x60	44	47	44 47
100x100	42	43	41 43

COEFFICIENT OF UTILIZATION						
pfc pcc pw RCR	20		70		50	
	70	50	30	70	50	30
0	101	101	101	98	98	98
1	93	89	84	90	86	83
2	84	78	72	82	77	71
3	78	68	63	76	68	61
4	70	61	54	68	59	54
5	66	55	47	64	54	46
6	60	50	41	58	48	41
7	56	45	38	55	45	38
8	53	40	34	51	40	34
9	48	38	30	47	36	30
10	46	34	28	45	34	28

LIGHT DISTRIBUTION			
DEGREES	LUMENS	% LAMP	% FIXTURE
0-30	2163	25.3	29.8
0-40	3573	41.8	49.2
0-60	6064	70.9	83.6
0-90	7253	84.8	100.0

LLF = 0.75 LLF = LIGHT LOSS FACTOR LLF = LDD X LLD X BF LDD = VERY CLEAN 0.94 CLEAN 0.90
 LLD = 0.91 @ 40% RATED LAMP LIFE BF = 0.88 ELECTRONIC BALLAST & T-8 LAMP (RELAMP AT 70% LAMP LIFE)

DIMENSIONS

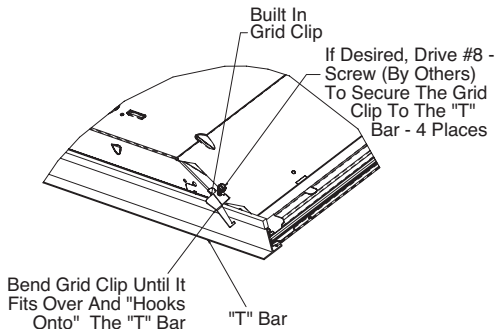
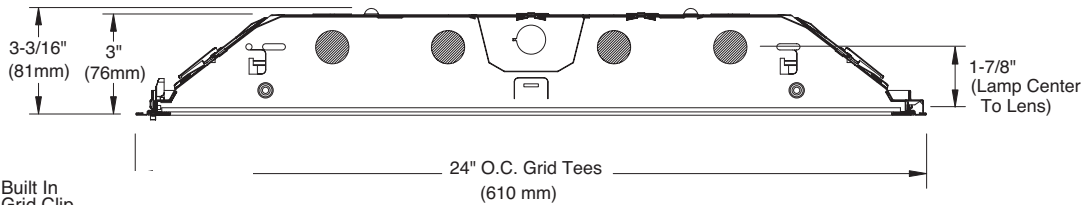

Wraparound Grid Clips

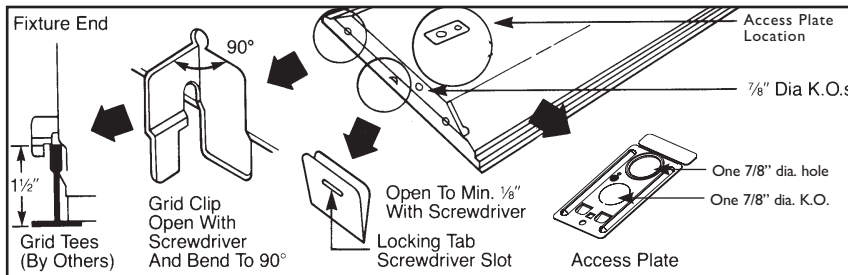

Fold-Out Grid Clips

PHOTOMETRIC DATA

CATALOG # 2TG8432-01-1/4-EB
TEST #22910 S/MH=1.4

LAMPS = F32T8
BALLAST = ELECTRONIC BALLAST FACTOR = .88

INPUT WATTS = 112

LER = FL-74
TER = 65

COMPARATIVE YEARLY LIGHTING ENERGY COST PER 1000 LUMENS = \$3.24 BASED ON 3000 HRS. AND \$.08 PER KWH.

FIXTURE EFFICIENCY= 82.9%

CANDLEPOWER				
Angle	End	45	Cross	
0	3551	3551	3551	
5	3559	3546	3527	
10	3514	3517	3519	
15	3433	3475	3505	
20	3316	3404	3473	
25	3158	3299	3410	
30	2964	3160	3312	
35	2735	2963	3154	
40	2461	2695	2904	
45	2140	2364	2568	
50	1781	2011	2137	
55	1426	1630	1718	
60	1097	1223	1304	
65	819	835	945	
70	619	539	672	
75	487	371	472	
80	368	287	335	
85	204	178	190	

MAINTAINED ILLUMINATION TABLE- Square Feet/ Fixture*						
<ul style="list-style-type: none"> 80-50-20 Reflectances (Ceiling-Wall-Floor) LLF = 0.75 2850 Lumens/Lamp very clean Room width divided by room height = 5 or more, 2 or 1 						
Fixture Size & # of Lamps	Room Width Room Height =	Approx. Area (sq. ft.) per Fixture				
		10 ft-c	30 ft-c	50 ft-c	70 ft-c	100 ft-c
4-Lamp T8	5	-	-	149	107	75
	2	-	-	104	74	52
	1	-	127	76	54	38

*Observe Fixture S/MH Requirements for Specific Applications

AVERAGE LUMINANCE CD/SQ.M WITH 2850 LUMEN LAMPS				
ANGLE	END	45°	CROSS	
45	3804	4041	4319	
55	2985	3205	3367	
65	2248	2165	2331	
75	1955	1603	2214	
85	2503	2156	2850	

TYPICAL V.C.P.'s					
Room Size	Mounting Height				
	8.5	10	8.5	10	
30x30	45	50	44	49	
40x40	41	45	41	45	
60x30	48	52	47	51	
60x60	37	40	38	41	
100x100	35	37	35	37	

COEFFICIENT OF UTILIZATION												
pfc pcc pw RCR	20			70			50					
	70	50	30	70	50	30	50	30	50	30		
0	98	98	98	95	95	95	92	92	92	92		
1	91	86	83	88	84	81	81	79	79	79		
2	82	76	70	81	75	69	71	68	68	68		
3	76	68	60	73	66	59	64	58	58	58		
4	69	59	53	68	58	53	56	51	51	51		
5	64	54	46	63	53	46	51	45	45	45		
6	59	48	41	57	47	40	46	40	40	40		
7	55	44	36	54	44	36	41	35	35	35		
8	51	40	34	50	40	33	39	33	33	33		
9	47	36	30	46	36	29	35	29	29	29		
10	45	34	28	44	34	28	33	27	27	27		

LIGHT DISTRIBUTION			
DEGREES	LUMENS	% LAMP	% FIXTURE
0-30	2834	24.9	30.0
0-40	4675	41.0	49.4
0-60	7911	69.4	83.7
0-90	9455	82.9	100.0

LLF = 0.75 LLF = LIGHT LOSS FACTOR LLF = LDD X LLD X BF LDD = VERY CLEAN 0.94 CLEAN 0.90
LLD = 0.91 @ 40% RATED LAMP LIFE BF = 0.88 ELECTRONIC BALLAST & T-8 LAMP (RELAMP AT 70% LAMP LIFE)



Some luminaires use fluorescent or high intensity discharge (HID) lamps that contain small amounts of mercury. Such lamps are labeled, "Contain Mercury" and/or the symbol "HG". Lamps that contain mercury must be disposed of in accordance with local requirements. Information regarding lamp recycling and disposal can be found at www.lamprecycle.org



© 2014 Koninklijke Philips Electronics N.V. All rights reserved.
Specifications are subject to change without notice.
www.philips.com/luminaires

425-SR 02/14

Philips Lighting Company
200 Franklin Square Drive
Somerset, NJ 08873
Phone: 855-486-2216

Philips Lighting Company
281 Hillmount Road
Markham ON, Canada L6C 2S3
Phone: 800-668-9008